

Physical Dimensions

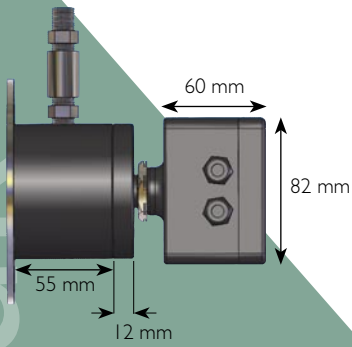

DV 425

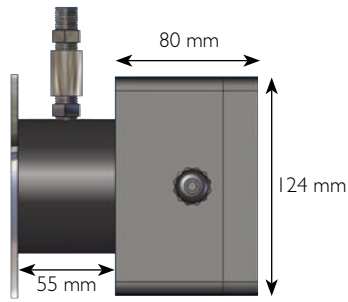

DV 428

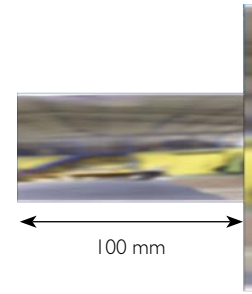

Stackmount

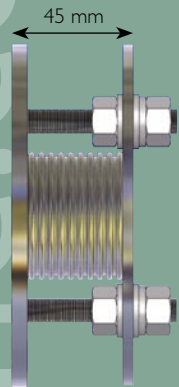

Alignment Aid

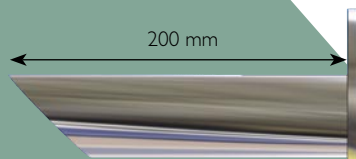

Anti-fouling fitting

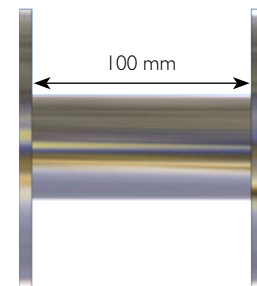

Extension Bobbin
(High temperature option)

Product Order Codes

DV-42X/XX

Stack Temperature
250 : up to 250°C
400 : up to 400°C

Stack Size
425 : up to 5m (flange to flange)
428 : up to 8m (flange to flange)

Option	DV425	DV428
Air Purge (pair)	DV425--ACCAIR	DV428--ACCAIR
DV Stack Mounts (pair)	DV425--ACC STACK	DV428--ACCSTACK
Anti-Foul Flanges (pair)	DV425--ACCANTIF	DV428--ACCANTIF

For stack diameters larger than 8m, please refer to SC602 data sheet

About PCME Ltd

As a progressive environmental Company, PCME specialises in particulate measurement for industrial processes. With a worldwide reputation for reliability, innovation and technological excellence, the Company produces equipment for concentration, velocity and mass monitoring for regulatory, environmental and process control requirements. A dedicated team of qualified application and sales engineers is always on hand and should be consulted in the selection and usage of the most suitable equipment for any particulate application.



PCME Ltd
Clearview Building, 60 Edison Road
St. Ives, Cambs PE27 3GH UK

Tel: Int +44 (0)1480 468200
Fax: Int +44 (0)1480 463400
E-mail: sales@pcme.co.uk

Contact your national or area sales and service office

PCME products are the subject of worldwide patents. Due to the continuing product development programme, PCME reserves the right to change any specifications without prior notice.



Particulate Monitoring Systems

Advanced Dynamic Opacity Monitors for
Particulate Monitoring in Emission Stacks

DV 425/428

Dust

Emission

Monitors



Certificate No: 9389

CE

- Suitable for stack sizes to 8m (product specific)
- In-built continuous compensation for dust on lenses due to Dynamic Opacity measurement principle
- Simple set-up via keypad operation
- Operates in high and low dust concentration
- Unique anti-fouling system minimising contamination from sticky particulate

What it does

The DV425/428 are microprocessor based optical measuring systems, which use a dynamic sensing technique to measure the rate of change of light (Dynamic Opacity) as particulates pass through an infrared light beam. This proven optical technique coupled with advanced design features offers significant reliability and resolution advantages over traditional Opacity monitors and virtually overcomes lens fouling associated with standard Opacity monitors. The DV425/428 meets European monitoring requirements and are suitable for continuous monitoring of particulate emissions from relatively large stacks, combustion processes, Electrostatic filters as well as other types of arrestment plant.

The DV425/428 series can be calibrated to offer outputs in mg/m^3 .* The DV425 is suitable for measuring emissions from stacks up to 5m. The DV428 extends this capability to stack sizes of 8m.

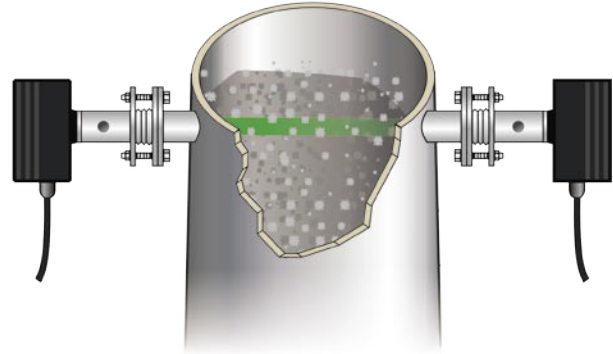

*Calibration is via comparison to an Isokinetic test

Principles of Operation

The DV425/428 continuous particulate monitors work on the principle of optical scintillation. This technique monitors the variation in the amount of received light from the light beam transmitted across the stack. The variation derives from the temporal distribution of particulate which attenuates the light beam. The DV425/428 calculates the dynamic response (ratio of light variation to light intensity or obscuration). This method has the added benefit that the measurement is unaffected by lens contamination. The instrument response which is proportional to dust concentration is used to calculate Ringelmann, extinction and can also be calibrated to read in mg/m^3 by reference to an Iso-kinetic sample (mass gravimetric technique).

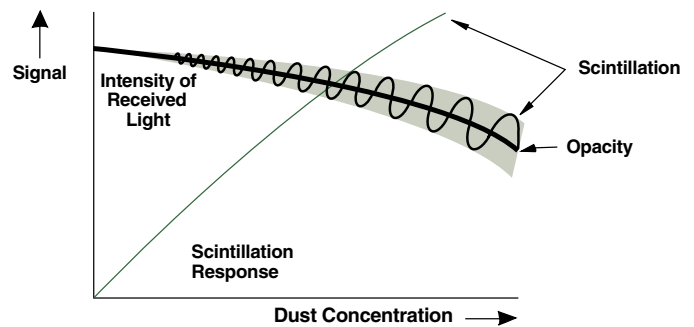

Technology Overview

The DV425/428 provides extended periods of operation without maintenance. In addition, the intrinsic technology benefits of the Dynamic Opacity technique is used to reduce or eliminate zero drift and stray light interference affects.

ZERO AND SPAN DRIFT

- The ratio of the signal scintillation to absolute light intensity is measured which compensates for any effects of lens build-up, misalignment or light source ageing. **Measurement in scintillation mode is unaffected until lens obscuration is greater than 90%.**

If the light intensity (I) is reduced by a contaminant coating on the lenses, the variation in intensity (x) is affected in the same proportion, giving no net effect.

- Air purges can be used to minimise build-up in the first place.

Lens condition	Light intensity	Variation	Scintillation
100% transmission	I	x	x/I
90% transmission	$0.9I$	$0.9x$	$0.9x/0.9I = x/I$
50% transmission	$0.5I$	$0.5x$	$0.5x/0.5I = x/I$

STRAY LIGHT

- A modulated light beam enables the detector to eliminate stray and ambient light effects.

Monitoring Range and Process Limits

	DV425	DV428
Stack Size (flange to flange)	1 to 5m	1 to 8m
Stack Gas Temperatures Option	Up to 250°C Up to 400°C	Up to 250°C Up to 400°C
Humidity	Up to 90% non condensing	Up to 90% non condensing
Dust Concentration	<10 to 10,000 mg/m ³	<10 to 10,000 mg/m ³
Resolution	0.2 mg/m ³	0.2 mg/m ³

Mechanical Specifications (Transmitter and Receiver)

	DV425	DV428
Stack Connection	DN40 PN6	DN40 PN6
Enclosure Rating	IP-65	IP-65
Enclosure Size	55mm x 75mm x 80mm	120mm x 122mm x 80mm
Transmitter and Receiver Materials	316 Stainless Steel Die Cast Aluminium	316 Stainless Steel (Exposed to Flue Gas) and Die Cast Aluminium Enclosure
Air Purge Connection*	¼" BSP	¼" BSP
Anti Fouling fitting	optional extra	optional extra

* Option: requires external supply of 0.5 litres/min of dry, clean oil free instrument air

Cable Specifications

Cable Length: standard option	20m 300m (maximum) transmitter / receiver to control unit
Cable Type	8-core screened 8 cores of 7 x 0.22mm, overall screen, PVC Insulated Overall diameter 6.3mm

Control Unit Specifications

Functions

Display	Dust units, mg/m ³ , Extinction, Ringlemann
Channel Name	10 letter user defined
Security	3 Digit Password
Quality Assurance	Optics Status 0 to 100%
Calibration	Via an Isokinetic sample
4-20mA Output	Isolated (dust unit, mg/m ³)
Instantaneous or fault alarm	SP Relay 2A @ 250 VAC, 30V DC Resistive Load
Average Alarm	SP Relay 2A @ 250 VAC, 30V DC Resistive Load
Inputs	Plant stop signal (output and display to 0 when plant off)

Mechanical/Electrical (Control Unit)

Enclosure Rating	IP-65
Enclosure Size	260mm x 160mm x 90mm
Enclosure Weight	3kg
Enclosure Material	Die cast Aluminium
Power Supply	115/230VAC, 50/60Hz
Fuse Rating	250mA
Display	Backlit LCD
Ambient Temperature Rating	-10°C to 50°C
Sensor Connections	Provides power and communications to sensors

Instrument Specifications

Response Time	<10 sec, 15% change (user defined)
Self-Checks	Automatic lens contamination reduction
Light Source	Modulated LED's (infrared spectrum)